

Fig 1

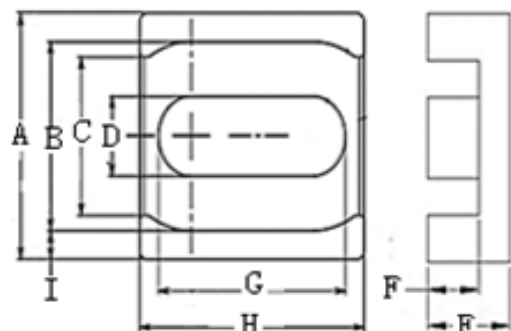

Fig 2

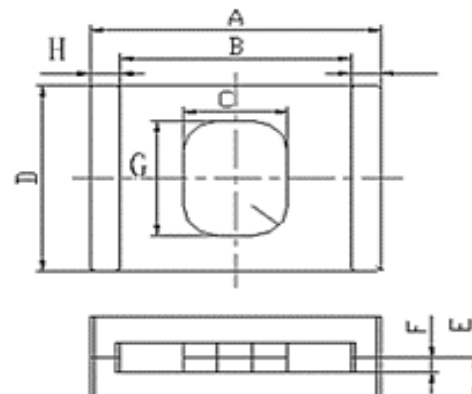

Fig 3

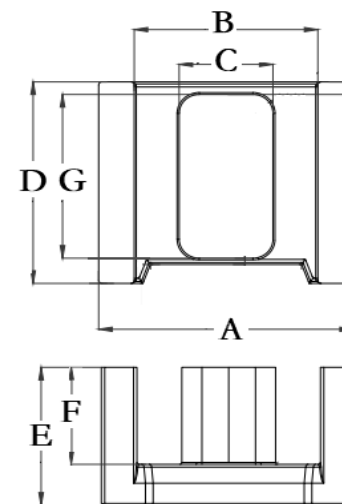

Fig 4

ED型

尺寸Dim 型号 Type	图形 Fig.	A (mm)	B (mm)	C (mm)	D (mm)	E (mm)	F (mm)	G (mm)	H (mm)
ED11	3	11 ± 0.2	8.6 ± 0.2	3.4 ± 0.15	7 ± 0.2	2.8 ± 0.1	1.6 ± 0.15	5 ± 0.15	—
ED23.6	1	23.6 ± 0.35	20.4 ± 0.35	11 ± 0.25	18 ± 0.3	4.5 ± 0.2	1.7 ± 0.2	5 ± 0.15	—
ED27.7	1	27.7 ± 0.35	23.7 ± 0.35	13.50 ± 0.2	11.40 ± 0.2	3.60 ± 0.1	1.35 ± 0.15	3.50 ± 0.1	—
ED27.1	2	27.10 ± 0.5	20.80 ± 0.4	17.50 ± 0.4	8.80 ± 0.2	11.15 ± 0.1	7.15 ± 0.15	25.0 ± 0.3	—
ED33	3	33.0 ± 0.4	26.2 ± 0.35	11.80 ± 0.15	25 ± 0.3	5.5 ± 0.1	2.0 ± 0.15	15.5 ± 0.2	3.4 ± 0.18
ED37	3	37 ± 0.4	30.2 ± 0.4	11.8 ± 0.15	25 ± 0.3	5.8 ± 0.1	2.3 ± 0.2	15.5 ± 0.2	3.4 ± 0.2
ED38	3	38 ± 0.5	30 ± 0.5	15 ± 0.25	26.6 ± 0.4	18 ± 0.2	14 ± 0.2	14 ± 0.2	—
ED38	4	38 ± 0.5	27.4 ± 0.5	14 ± 0.25	32 ± 0.5	21.9 ± 0.2	15.4 ± 0.2	26 ± 0.35	—
ED46.5	3	46.5 ± 0.8	36.5 ± 0.8	20 ± 0.35	10 ± 0.35	40 ± 0.2	35 ± 0.25	5 ± 0.2	—